

Desalination for Saudi Arabian Refinery

Overview

Aquatech is supplying the equipment for two (2) 525 gpm seawater distillation system to Saudi Arabian Oil Company's Ras Tanura Refinery in Saudi Arabia.

General Project Description

Aquatech was successful in meeting the strict guidelines of Technical & Delivery requirements.

In general the infrastructure was made capable of supporting the needs of up to new 525 US GPM desalination units.

The evaporator is a four effect thermal vapor compression system with the following conditions:

- Seawater temperature range from 48°F to 95°F.
- Seawater TDS 51,000 ppm.
- Distillate (final product from MED unit) purity 5 ppm TDS.
- Design capacity of 525 USGPM with turndown to 50% of design capacity.

Operate at a Gain Output Ratio of 6.5 kg of distillate/kg of steam input to the thermocompressor

The most important feature of Ras Tanura Project is the Superior Metallurgy of Components of MED plant.

Shell, all 4 effects : UNS S 31254 (SMO 254)

Shell Internals - tubesheets, spray headers, supports : UNS S 31254 (SMO254)

MED Tubes: Titanium

Condensers Titanium

Ejectors : UNS S 31254 (SMO 254)

Valves & Instruments : SMO 254 / SS 317L / Monel etc.



Aquatech's Multiple Effect (MED) Thermal Vapor Compression design is a 4 effect unit which incorporates SPRAY-FILM® technology, a registered trademark of Aquatech. Aquatech's MED design is the result of over 25 years of experience in the design, manufacture, start-up and operation of MED evaporator systems worldwide.

For this system, steam or water vapor condenses inside horizontal tubes. Seawater is sprayed over the outside of the horizontal tubes and acts as a heat sink for the condensing vapor. The latent heat of vaporization transfers from the water vapor through the tube wall to the thin seawater film on the outside of the tubes. For every pound of water vapor that condenses, approximately one pound of water evaporates from the seawater film once the seawater has reached the saturation temperature.

SPRAY-FILM® technology offers superior quality seawater distribution via spray nozzles over the tubes. The spray nozzles ensure that the seawater flows uniformly and generously over the heat transfer surface. The seawater feed flow rate in this system is conservatively designed to keep the heat transfer surface well wetted.

PROJECT PROFILE SERIES #43

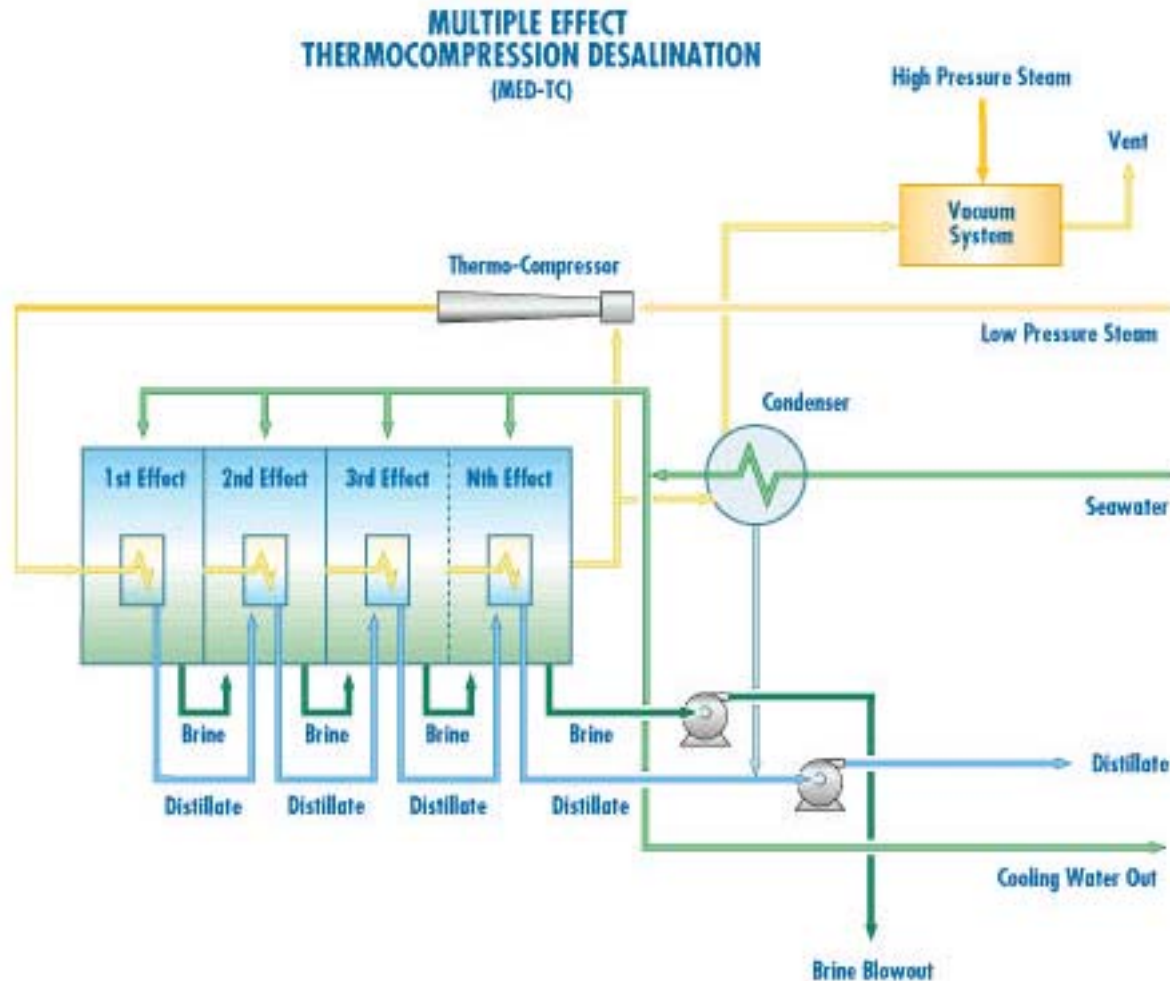

The vapors evaporated from the seawater will contain significant quantities of noncondensables, specifically CO₂ and air. There will also be air leakage. These noncondensables will flow with the vapor into the steam chest of the next effect. As the steam condenses, the noncondensables will stay in the vicinity of the tube wall unless swept away by high velocities. Having this vapor on the inside of the tubes is an advantage of the SPRAY-FILM® design. SPRAY-FILM® evaporators maintain high vapor velocities within the tubes without the need for expensive and complicated baffling. Splitting the tube bundle by approximately 90% in the first pass and 10% in the second pass, ensures that the noncondensables flow continuously to the vent line. This technique maintains high heat transfer coefficients and prevents loss of driving force (differential temperature) by minimizing excessive subcooling of the heating vapor.

The system operates under a vacuum with a top brine temperature of 140°F. By operating at low temperatures, the heat transfer surface is less likely to scale, and the amount of heat required to bring the incoming seawater to its boiling point is minimized.

This Multiple Effect plant incorporates the use of a thermocompressor to improve the thermal performance of the plant. The thermocompressor is driven by high pressure steam which entrains and boosts lower pressure vapors from the last effect to the moderately higher pressure condition required in the first effect to operate the process. By recycling the lower pressure vapors from the last effect with a thermocompressor, less steam is required from an external source than if there were no thermocompressor.